

User Manual

Solid-State HF Band
200W Linear Power Amplifier

Model HL-200BDX

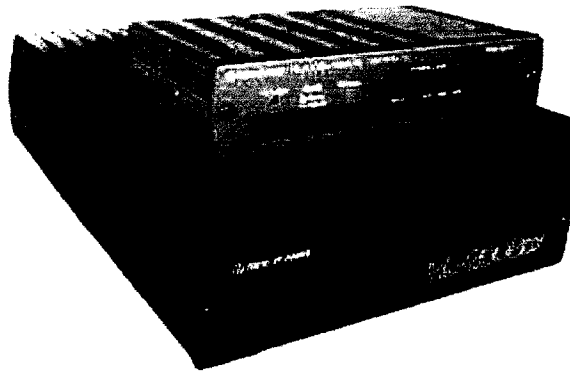

(1) HL-200BDX/FEATURES

- HL-200BDX is a solid-state HF band linear amplifier with the maximum output power of 200W. It can be driven by 10W, 50W and 100W transceivers respectively. Four pieces of RF power transistor ,THP-120, developed by Toshiba are used in parallel push-pull form. THP-120 has an ideal performance for SSB operation with its excellent linearity.
- Separate remote controller enables the remote controlling for on and off of power switch, band select etc.
- Output low-pass filters are equipped for each frequency band , and harmonics are effectively suppressed.
- RF keying circuit (or carrier operated send-receive switch) is equipped. Also HL-200BDX has a socket for switching signal from transceiver to make combined send-receive switching with transceiver (master/slave send-receive switching).
- WARNING circuit is provided. When the improper band-setting and antenna open/short are detected, protection circuit works to avoid troubles. WARNING lamp of the controller will light.
- Protection circuit for heat-sink over heating provided. When the heat sink is over heated, protection circuit will stop the amplifier to cool down to the normal temperature. (External cooling fan , HBK-110F is optionally available.)
- LED power level meter will always indicate the output power level.

(2) SPECIFICATIONS

Frequency	:	HF Band (3.5 ~ 28 MHz Band)
Mode	:	SSB, CW, FM (*AM)
RF Drive Power	:	10W, 50W, 100W Manual select.
RF Output Power	:	200W p.e.p. (180W when driven with 10W)
In/Out Impedance (Zin/out)	:	50 ohms (unbalanced)
Final RF Power Transistor	:	THP120 x 4 (by Toshiba/THP)
Amp. Circuitry	:	Class AB Parallel/ Push-pull
DC Power	:	DC 13.8V, 40A max.
In / Out connectors	:	Type SO - 239 (or M - J)
Dimensions	:	Amp. 180 x 70 x 290 mm (WxHxD) Controller 150 x 35 x 85 mm
Weight	:	Amp approx. 3 kgs. (6.6lbs.), controller 0.4 kgs (0.88lbs)
Accessory Parts	:	Remote controller cable , DC power cord, RCA Plug (2 pcs.), Spare Fuse 20A (4 pcs.), Screw bolts M4 x 10 (4 pcs.)
Cooling Method	:	Natural Air Flow

(* AM, To be kept 50W max.)

(3) Front and Rear Panels of R. Controller

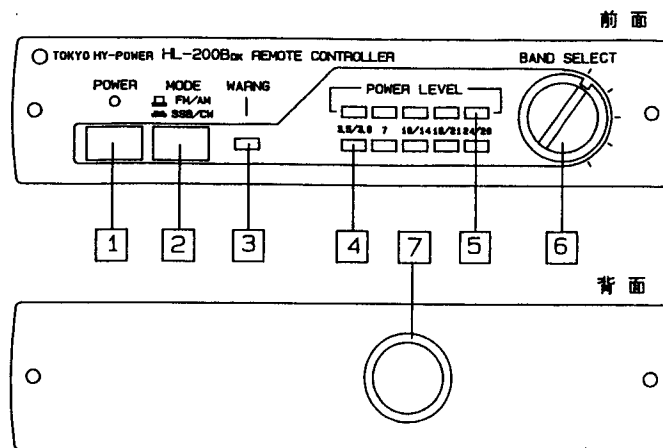

FRONT PANEL

- ① **POWER** : ON/OFF switch for DC power. When it is once pushed, the switch is locked for "ON". If it is pushed again, the lock will be reset for "OFF".
- ② **MODE (Select switch for SSB/CW, FM/AM)** : This switch selects the time lag of rf keying circuit, when the amp changes from TX to RX. When pushed to "SSB/CW", lag is about one second, and at FM/AM position, there is no time lag.
- ③ **WARNG (Warning)** : Warning circuit will work to protect the amp in such cases when the band switch is not selected properly, and antenna is short, open etc. Correct the trouble and turn on the power switch.
- ④ **BAND** : LED indicator for band in operation.
- ⑤ **POWER LEVEL** : Five LED's indicates approximate transmitting power level. When all LED lights, it means power out is approx. 170W or more.
- ⑥ **BAND SELECT** : To select the proper output low-pass filter for desired frequency band of operation.
- ⑦ **CONNECTOR SOCKET** : Use the special cable supplied in a carton box to connect amp and controller.

(4) AMP (REAR PANEL)

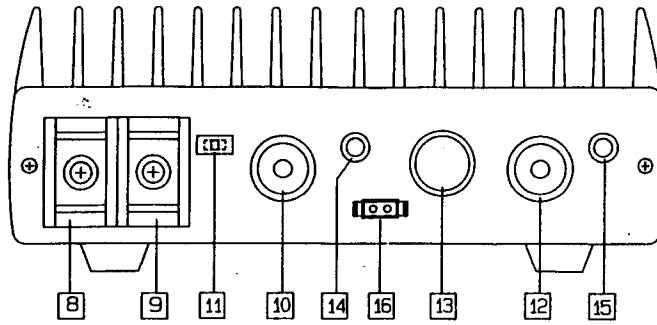

- ⑧ ⑨ DC 13.8V TERMINAL : Using the DC power cord supplied, connect to either regulated DC power supply, or DC 12V battery. ⑨ RED (positive), ⑧ BLACK (negative). DC current capacity should be 40A (peak) minimum.
- ⑩ TX (RF Input Connector) : Connect a coaxial jumper cable from the transceiver
- ⑪ RF Input Level Select Switch : Select the proper rf driving level according to the transceiver used.
- ⑫ ANT (RF Out Connector) : Connect the antenna cable.
- ⑬ ACC1 (Socket for Separate Controller) : Connect the controller cable and it will enable you to remotely operate the amplifier.
- ⑭ ACC2 (Stand-by jack/ TX Keying jack) : You can connect to "Remote" or "ACC(accessory)" socket of your transceiver and forced TX keying will be achieved in conjunction with transceiver keying. (It is recommended for ssb/cw operation.)
- ⑮ ACC3 (ALC socket) : Connecting to ALC socket pin of the transceiver , over-driving of the amp will be avoided. Also, output level can be kept within the maximum limit. Negative DC voltage of 0 to - 10V will appear at the socket pin. Check that the transceiver will accept this negative ALC DC signal. For the proper output level, it is needed to adjust the ALC adj. variable resistor at certain point in order to limit the output power level. (See the following illustration.)
- ⑯ Socket for HBK-110F : Connect the connector from the HBK-110F (optional mounting bracket with cooling fan) to supply DC 13.8V power for the fan.

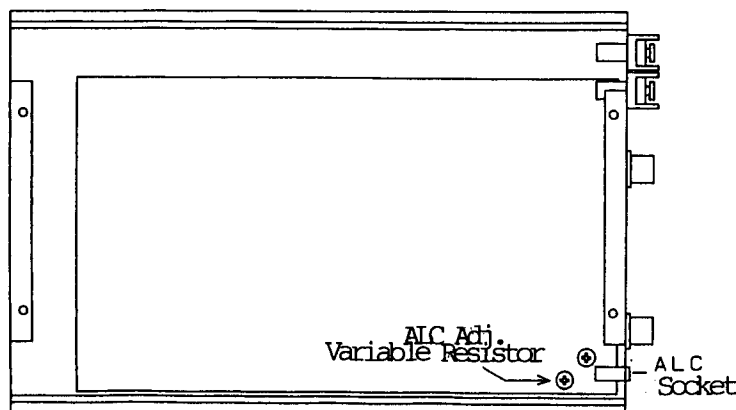

(5) SETTING / OPERATION

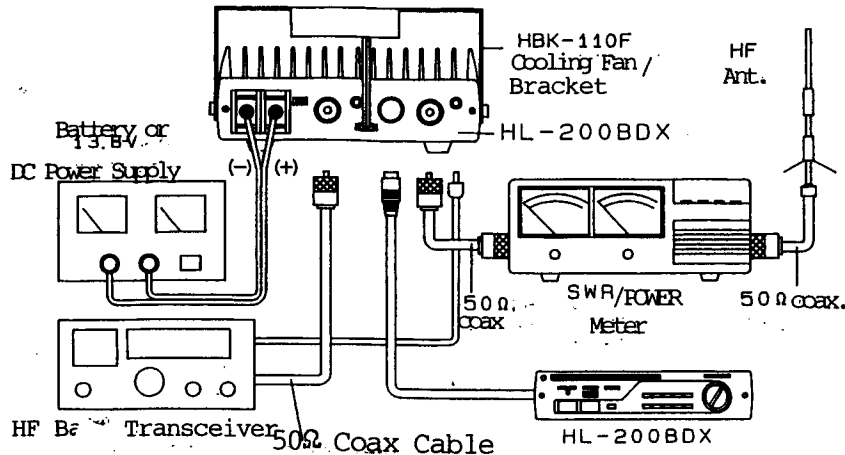

- ① Referring to the illustration, connect your transceiver, amp. , controller, power supply, SWR/Power meter, antenna etc. properly. It is recommended that antenna is well adjusted for good SWR value such as 1.5 or lower.
- ② Set the RF input level select switch ⑪ according to the output level of the transceiver.
- ③ Set the Band Select Switch ⑥ properly to the desired operating frequency band.
- ④ Turn on the DC POWER switch ① .
- ⑤ If you key (transmit) the transceiver, HL-200Bdx amplifier will also be automatically keyed to transmit with the function of rf key circuit . Then the amplified signal is emitted from antenna. At this time, LED's of POWER LEVEL INDICATOR will light according to the transmitting signal level.
- ⑥ Depending on the transmission mode, set the MODE SELECT SWITCH to either FM/AM or SSB/CW. When HL-200Bdx is operated with rf key circuit (carrier operated send-receive switching) for ssb , TX state will be switched to RX , if you stop talking.
- ⑦ For the smoother and fast TX/RX switching, it is recommended that you will utilize ACC2 to connect to "Remote" or "ACC" socket of the transceiver. (In this case, Mode Select Switch should be set to FM/AM.
- ⑧ When the heat sink temperature exceeds 70 deg. C , the amplifier will stop working due to the internal protection circuit. In this case, please wait for a while until the temperature becomes low enough so that the power switch can be turned on again. (for information, external cooling fan with bracket HBK-110F is available as an optional parts.)
- ⑨ If you are going to operate without HL-200Bdx amplifier (or "on bare-foot"), leave the coaxial jumper cable connections as they are, and just turn off the power switch. And all the signals coming in and out of the antenna will by-pass the amplifier.

PLEASE NOTE THAT THE 13 PIN HEAD UNIT CONNECTOR IS A REGULAR 13 PIN DIN WITH ONE to ONE Connections

Updated 1 Feb 2019

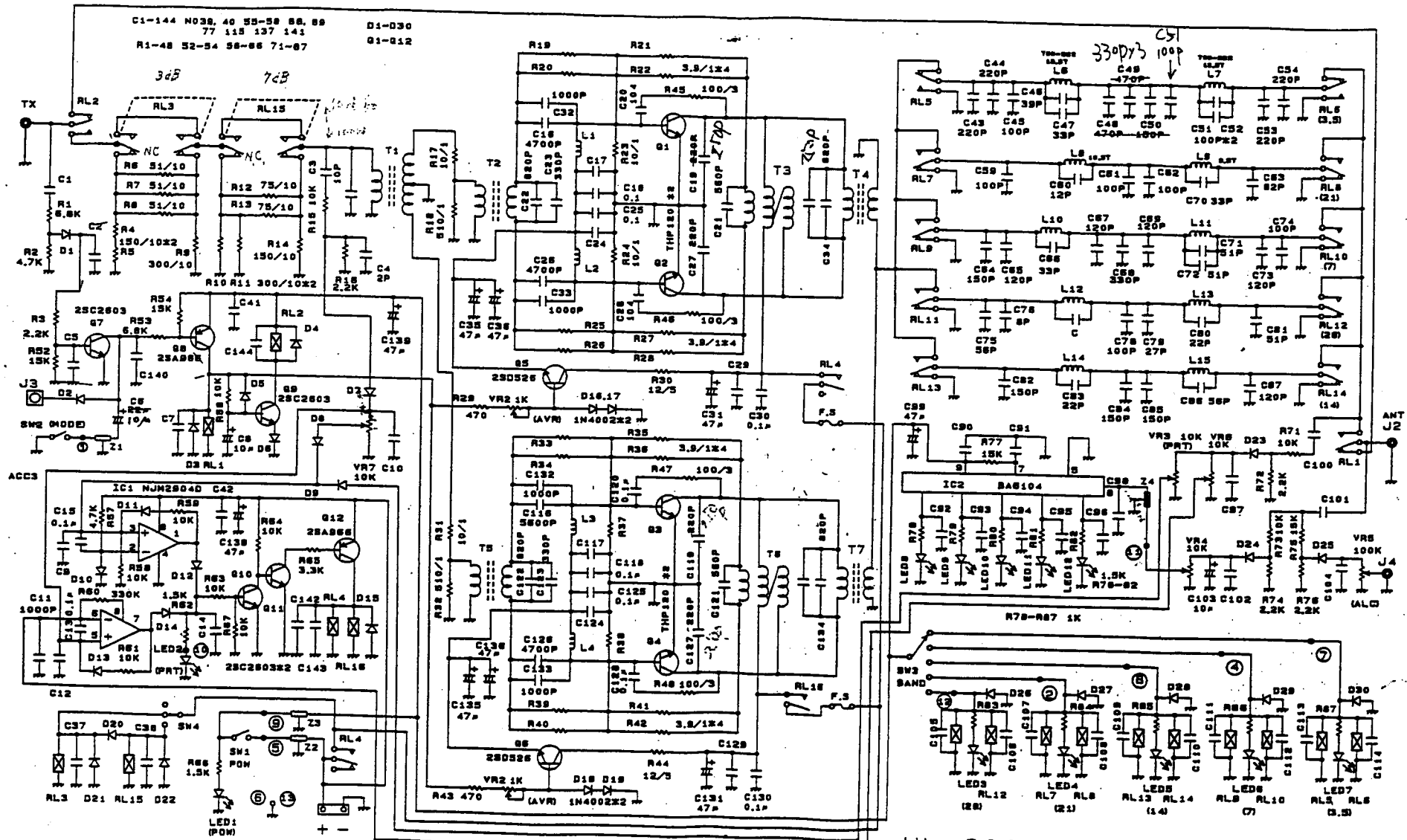

C1-144 N038, 40 55-58 88, 89
 77 118 137 141
 R1-48 52-54 58-66 71-87
 D1-D30
 Q1-Q12

- 指定なダイオードは1S2076
- 容量指定なコンデンサは0.01μF
- ⑬は ACCのPIN番で、

SW4
 100
 50
 10
 V

HL-200B_{DX} CIRCUIT DIAGRAM